

Flooring Complements

# Floor Box



08/2021 BE BT EN 5

**Schotten  
& Hansen**

Nature Refined.

# Floor Box

## Product specifications

<b>Description</b>	Schotten & Hansen floor box with flush lid and with electrical and data connection modules, consisting of: Anodized aluminum casing 5 mm with grounding terminal in compliance with VDE Height adjustable articulated feet Cover with stainless steel or brass cable outlet Panel  Additional features: Floor level flush Without peripheral frame Adaptable to width of floor boards No impact sound transfer as a result of acoustic decoupling
<b>Panel Variants*</b>	Panel with device unit power socket (ready to connect casing) Panel with device unit data outlet (ready to connect casing) Blind panel for empty sockets/cavity sockets** d = 68 mm Panel VL.BT.08 without chasing
<b>Assembly</b>	Easy assembly during floor installation for existing screed/hollow flooring
<b>Construction Requirements</b>	Screed/hollow flooring height $\geq 110$ mm Total installation height*** $\geq 131$ mm Dry zone Screed/hollow flooring Floor covering thickness: 19 mm Traffic load $\leq 3$ kN/m
<b>Dimensions Floor Recess F</b>	see Dimensions
<b>Dimensions Floor Box</b>	see Dimensions
<b>Specifications</b>	not suitable for wet rooms

\*Optional

\*\*Coordinated with the power socket covers from Gira and Busch-Jaeger; not included in shipment.

\*\*\*Measurements quoted refer to a plug height of 40 mm and are subject to change for greater plug heights.

# Floor Box

## Dimensions\*

	A	B	C	custom D	E	F
	Clear Width	Clear Length***	Height Min./Max.	Electrical Connections	Data Ports	Floor Recess W/L
VL.BT.01	200	240	132 / 260	0	4	300 / 340
VL.BT.02	200	320	132 / 260	3	0	300 / 420
VL.BT.03	240	320	132 / 260	3	4	300 / 420
VL.BT.04	240	320	132 / 260	6	0	300 / 420
VL.BT.05	200	200	132 / 260		4*	300 / 300
VL.BT.06	200	280	132 / 260		6*	300 / 380
VL.BT.07	280	280	132 / 260		9*	380 / 380
VL.BT.08**	200 - 320	200 - 320	132 / 260	custom	custom	300 - 420 / 300 - 420

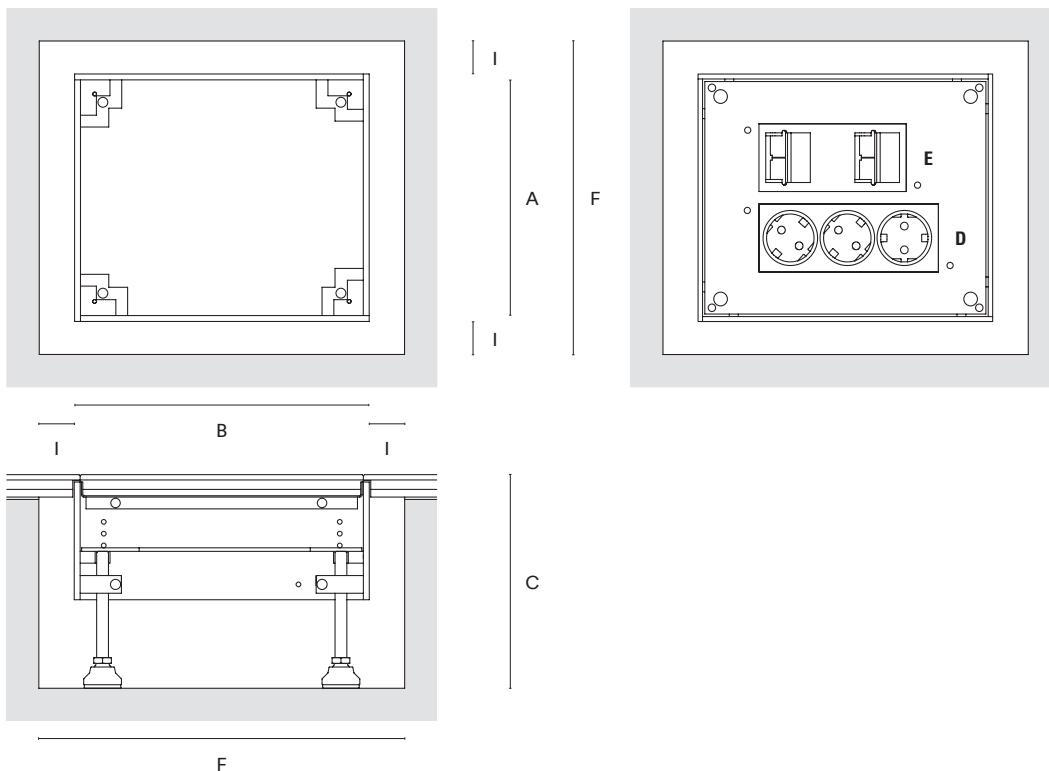

All data quoted in mm /

\*Number of total connections

\*\*Individual configuration on site by electrician

\*\*\*Length in the direction of the floorboard

**Schotten  
& Hansen**

# Floor Box

## Design Variants

### Panel configuration

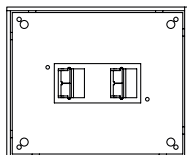

VL.BT.01 200 × 240 mm\*  
quadruple data socket

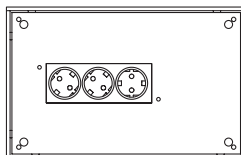

VL.BT.02 200 × 320 mm\*  
triple power socket

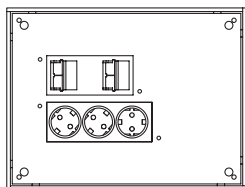

VL.BT.03 240 × 320 mm\*  
triple power socket  
quadruple data socket

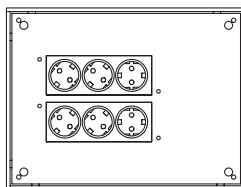

VL.BT.04 240 × 320 mm\*  
2 x triple power socket

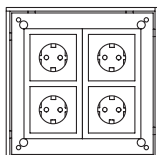
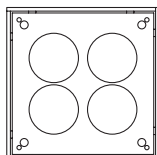

VL.BT.05 200 × 200 mm\*  
chasing for 4 cavity sockets  $d = 68$  mm,  
example configuration right

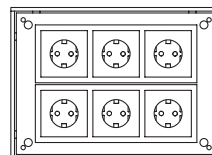
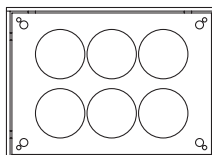

VL.BT.06 200 × 280 mm\*  
chasing for 6 cavity sockets  $d = 68$  mm,  
example configuration right

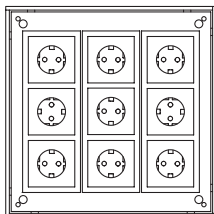
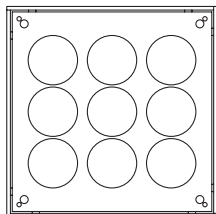

VL.BT.07 280 × 280 mm\*  
chasing for 9 cavity sockets  $d = 68$  mm,  
example configuration right

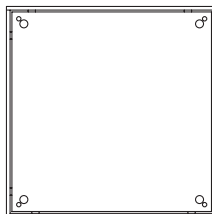

VL.BT.08\*\*  
without chasing (on site by electrician)

\*Clear interior dimensions | \*\*200–320 mm x 200–320 mm (40 mm grid)

# Floor Box

## Technical Data

### Layout Floor Box

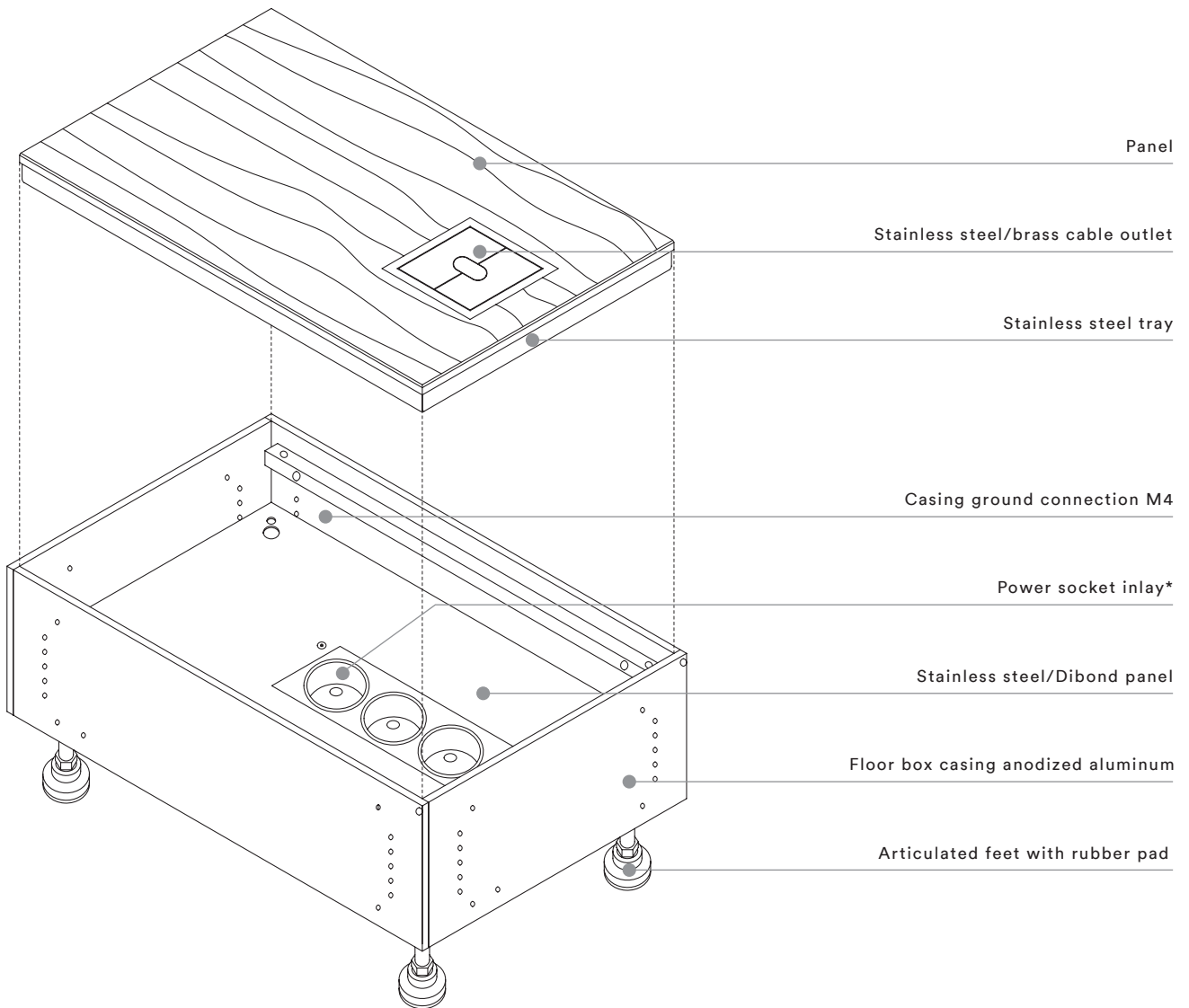

\*EVOline® by Schulte Elektrotechnik

**Schotten  
& Hansen**

Schotten & Hansen GmbH, August-Moralt-Straße 1-3, 86971 Peiting,  
T +49 8861 90804-0, kontakt@schotten-hansen.com, www.schotten-hansen.com

# Floor Box

## Technical Data

### Layout Floor Box Cover

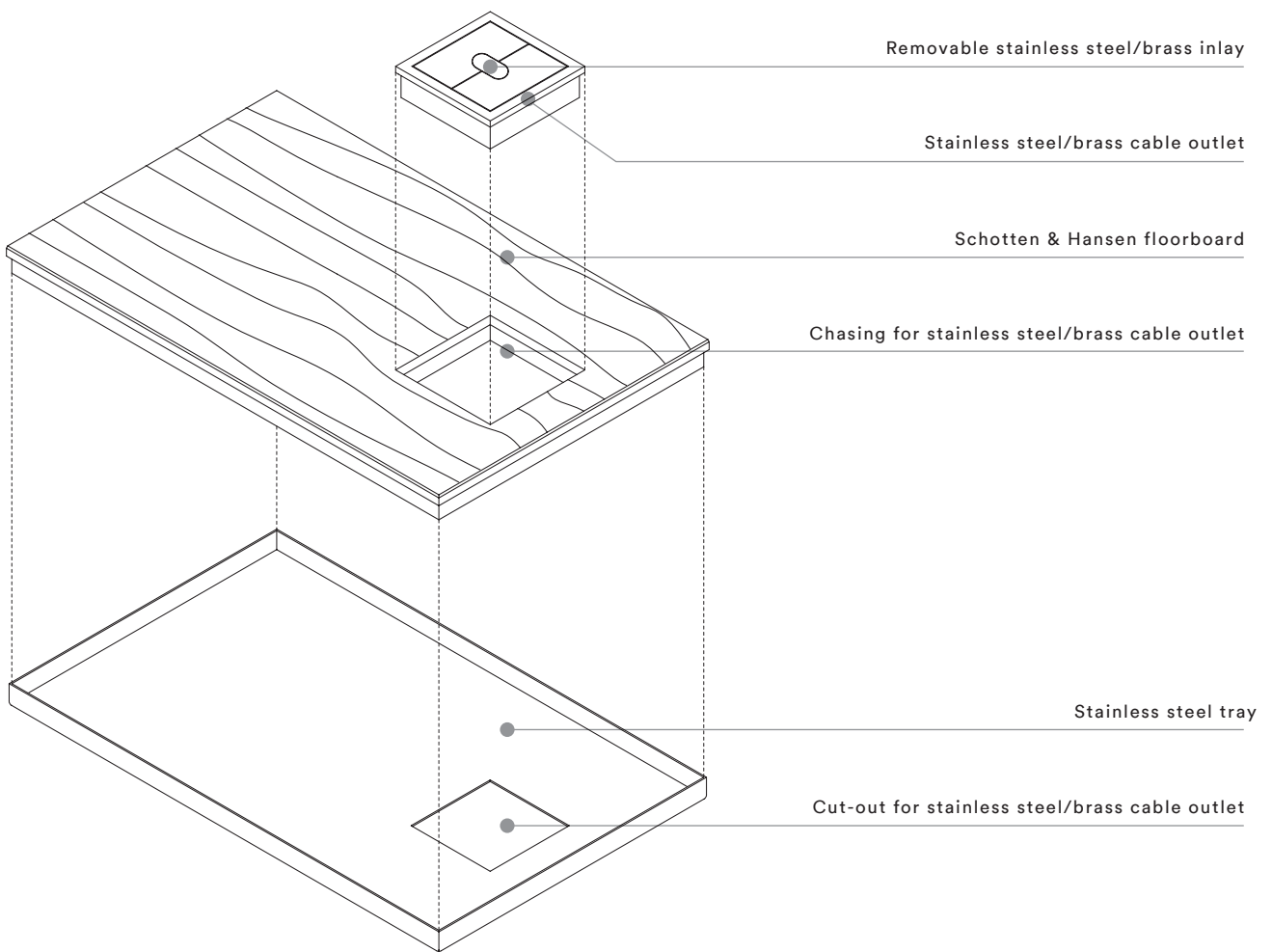

# Floor Box

## Technical Data

### Cross Section

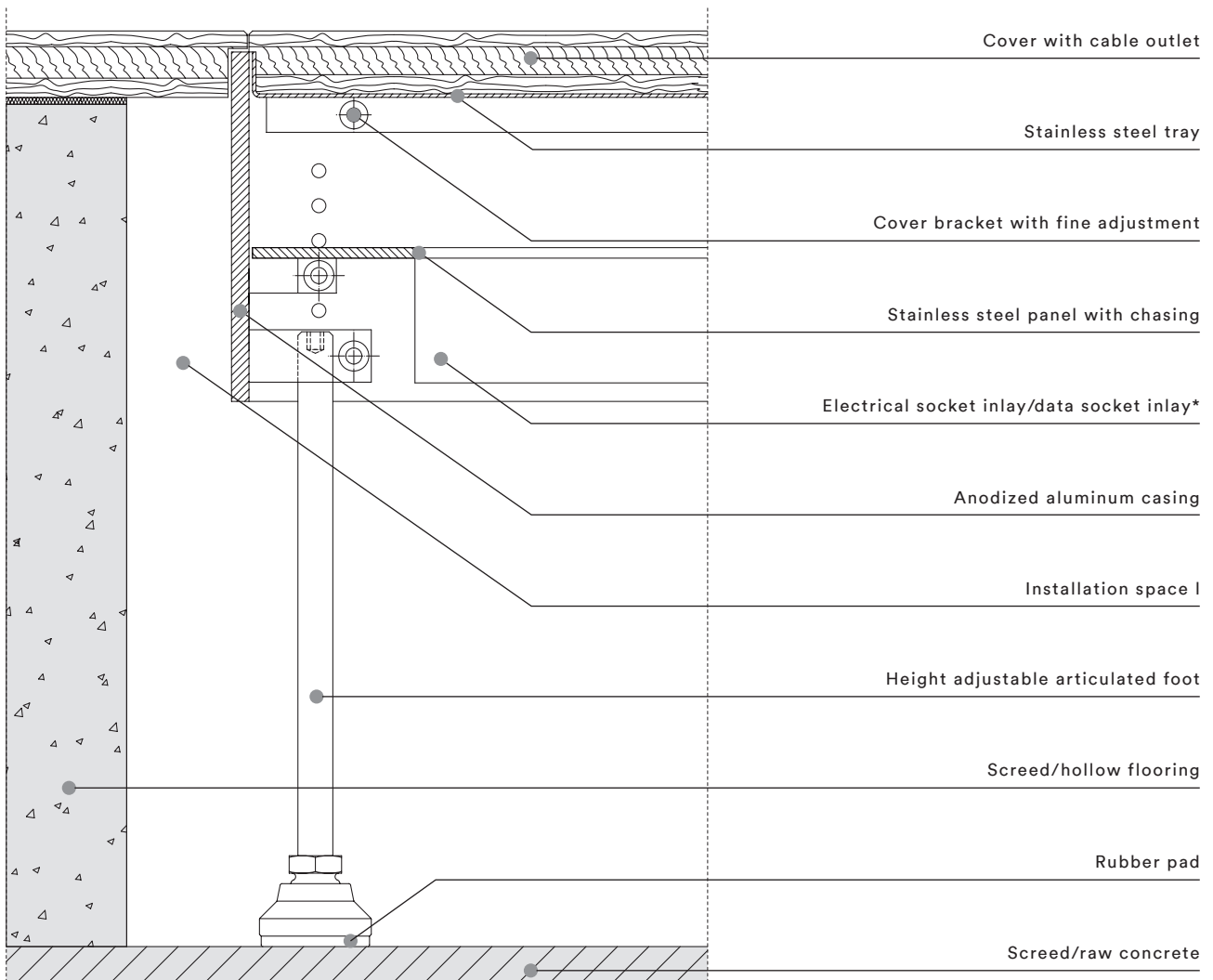

\*EVOline® by Schulte Elektrotechnik

**Schotten  
&Hansen**

Schotten & Hansen GmbH, August-Moralt-Straße 1-3, 86971 Peiting,  
T +49 8861 90804-0, kontakt@schotten-hansen.com, www.schotten-hansen.com

# Floor Box

## Assembly

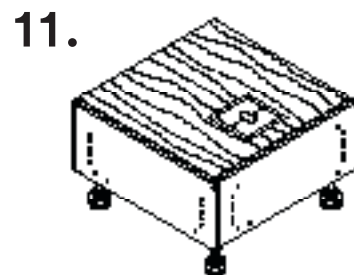
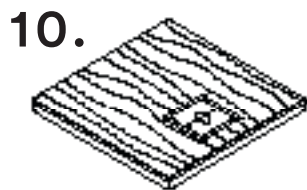
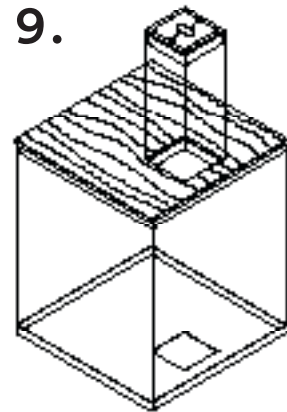
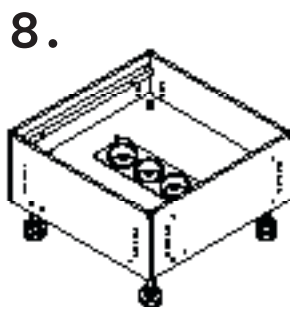
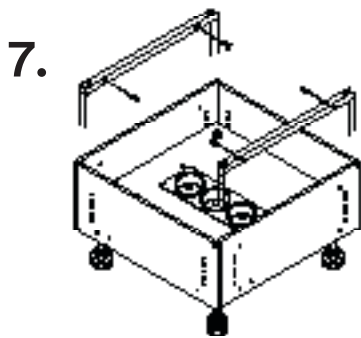
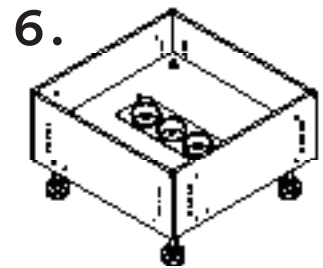
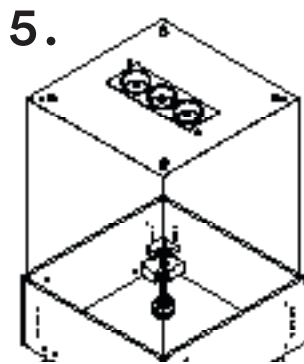
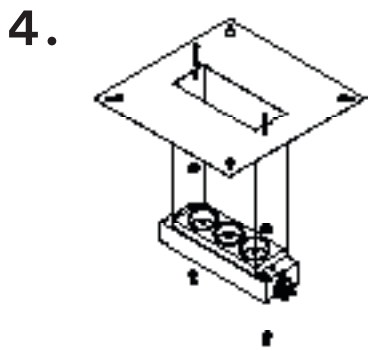
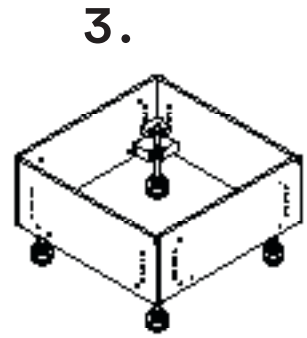
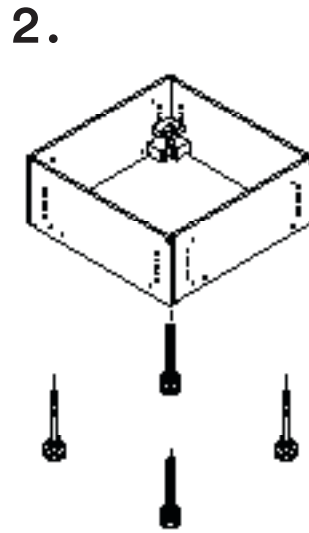
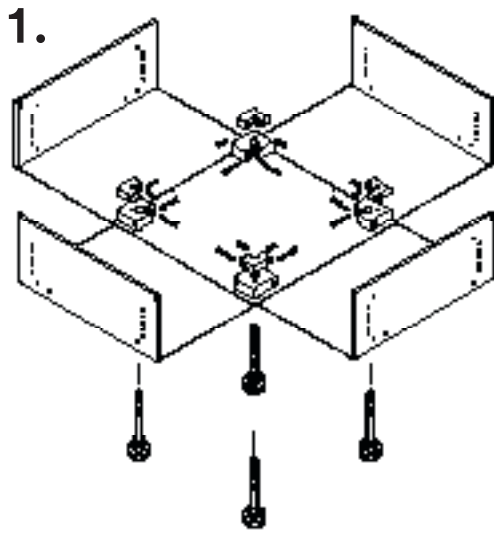

**Schotten  
& Hansen**



# Floor Box

## Assembly

1.

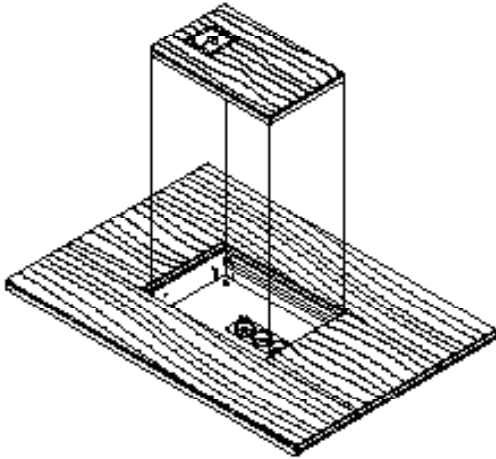

2.

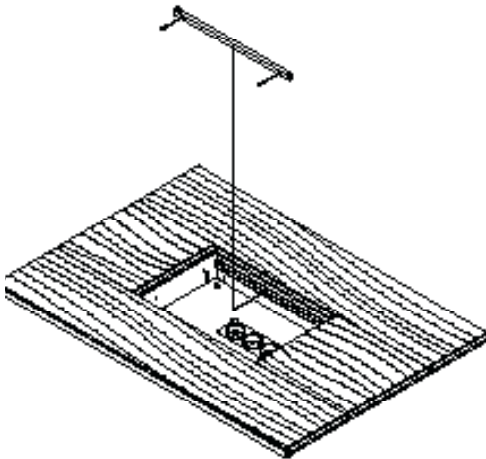

3.

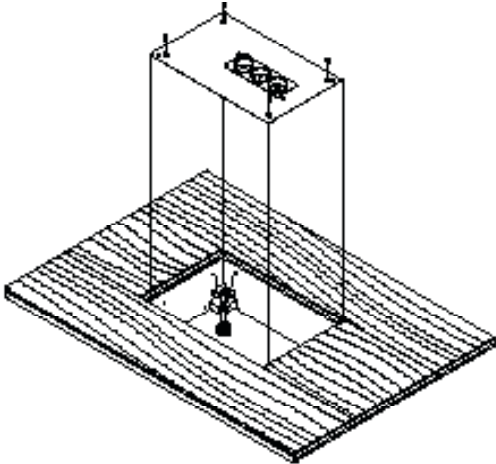

Cable outlet in stainless steel

**Schotten  
&Hansen**